



## CDD630JDSL - Ductile Iron Kitemark Manhole Cover & Frame

### KEY FEATURES

- BSI Kitemark certified to BS EN124 2015
- Double-seal design (manhole grease required to form seal, available separately, product code CD 285) for odour egress control
- Fitted with locking screws
- Integral keyholes



### CDD630JDSL - Specifications

Product Weight (Kg)	94
Cover Weight (Kg)	62
Clear Opening	600 x 600
Overall Dimensions	800 x 800
Frame Depth	125
Internal Tray Depth	100
Material	Spheroid Graphite Iron Grade EN-GJS-500-7 to BS EN 1563:2011 Temporary Bitumen based paint coating to BS 3416:1993
Load Rating	D400
Frame Pressure Bearing Area (N/mm <sup>2</sup> )	1.9
Application	Non carriageway use

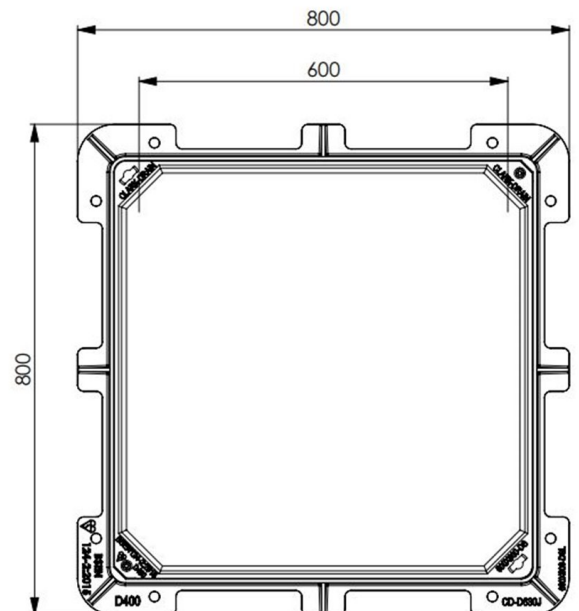

CDD630J-DSL/V0.1/14-06-2023

Due to our continuous product improvement program features and sizes may be subject to change without notice.

CLARK DRAIN, STATION ROAD, YAXLEY, PETERBOROUGH, PE7 3EQ, TEL. +44 (0) 1733 765317